



D.I.D.[®]
CATALOGUE

Power Transmission Chain
Products guide
European Version

MADE IN JAPAN
QUALITY



DRIVEN TO SOLUTIONS **The D.I.D Brand**

Known for its **D**urability and Dependability **I**n **D**esign.
As established technical innovator in the world chain drive market, serving a broad spectrum of industries with quality products for over 80 years.

That is **D.I.D.**

Our technology turns timely ideas into productive realities.
D.I.D is a professional partner you can count on for your optimum drive system solutions.

--- INDEX ---

European Standard Roller Chain	···P3
ANSI Standard Roller Chain	···P4
O-Ring/X-Ring Chain	···P6
Ultimate Power Chain	···P8
Double Pitch Chain	···P12
Environment Resistant Chain	···P13
Stainless Steel Chain	···P15
How to order DID Chain	···P17

DID is a brand you can depend on.

Certified management system in conformity with world standards.

Quality assurance and environmental management system authorized domestic and overseas standards.

DID's Quality Assurance

- Customer satisfaction is our priority.
- All DAIDO members are committed to quality.
- Quality control based on facts is assured.

With activities based on these quality policies, our quality assurance system is internationally authorized to state that our products conform to the ISO9000 series and API.



ISO9001/2000 Certification

It is indispensable to obtain the Certification of ISO9001/2000 for supplying products to overseas markets - not only Europe and the US but also other countries. Our entire production system, including design, development, manufacturing, installation and technical assistance for all of our products including various chains, conveyor systems and welfare equipment, has been certified by the Japan Quality Assurance Organization (JQA).



ISO14001 Certification

ISO14001 was established in 1996 by the International Organization for Standardization, to set requirements for environmental management systems. In order to preserve the global environment, reverse contamination and enhance the health of human beings and ecosystems, DAIDO declared our policies for environmental preservation. As a result, our management system for our activities, products and service for environmental protection was certified by the organization. We have been engaged in various activities for environmental preservation and improvement, such as reduction of waste and classification of waste for recycling, in accordance with our environmental policies.



Authorization by API

The American oil industry applies rigid quality control standards to all mechanical parts used in oil field development and oil refining. The organization that examines the conformity with their standards for authorization is called API (American Petroleum Institute). Since receiving authorization from API in 1972, we have been supplying DID roller chains and sprockets to many companies not only in the USA but also all over the world under our rigid quality control system.

Classification by use	Product No.	Functions							Main uses																	
		Allowable ambient temperature	High tension	Wear resistance	Dusty circumstances	Resistance against corrosive gas	Resistance against alkali, acid liquid	Hygiene circumstances	High temperature	Pack	Textile	Print	Home Appliance	Construction	Agriculture	Petroleum	Forestry	Excavation	Mining	Conveyor	Food	Beverage machine	Chemicals	Water Treatment	Chemicals/ Medical	
European (BS) Standard Roller chain	ISO-B	-10~80°C								○	○	○	○	○					○	○						
ANSI Standard Roller chain	ISO-A,ANSI										○	○	○	○	○					○	○					
European (BS) Standard O-Ring/X-Ring chain	BL NL BLX			○ ○	○ ○						○ ○	○ ○	○ ○	○ ○	○ ○					○ ○	○ ○					
ANSI Standard O-Ring/X-Ring chain	LD	-10~80°C	○ ○							○ ○	○ ○	○ ○	○ ○	○ ○					○ ○	○ ○						
	LF		○ ○							○ ○	○ ○	○ ○	○ ○	○ ○					○ ○	○ ○	○					
	LX	-10~120°C	○ ○					○		○ ○	○ ○	○ ○	○ ○	○ ○					○ ○	○ ○						
	LDSSP	120~200°C	○ ○					○	○										○ ○	○ ○	○					
Ultimate Power chain	HK		○											○ ○	○ ○											
	HI-PWR-S		○											○ ○												
	HI-PWR-S HK		○											○			○	○								
Double Pitch chain	ANSI TYPE	-10~80°C							○	○									○	○						
Environment Resistant chain	N				○						○	○							○	○		○				
	E				○						○	○							○	○			○			
	WG				○						○	○							○	○		○	○	○		
	SS	-10~400°C				○	○	○	○											○	○		○	○	○	
	SSK					○	○	○	○											○	○		○	○	○	
	SSLT	-10~200°C		○	○	○	○	○												○	○		○	○	○	

D.I.D DID ANSI Standard Roller Chain

The 14 sizes of DID standard roller chains are available ranging from DID25 to DID240 including those in conformity with ANSI (American National Standard Institute), and ISO (International Organization for Standardization). The chains not only meet the requirements for the minimum tensile strength prescribed by ANSI and ISO, but they also provide the top class quality in the world including a high fatigue strength.



Dimensional drawing

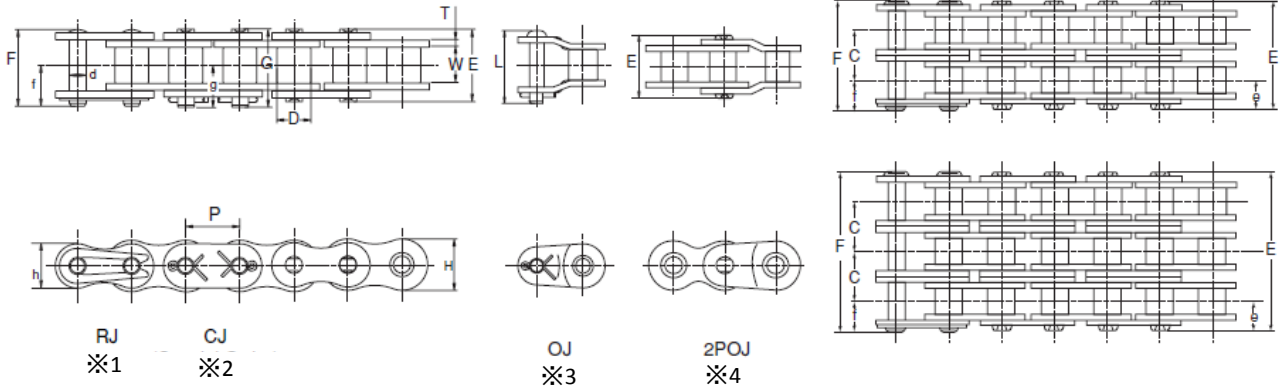

Dimensions

(mm)

Chain No.		Pitch	Roller link width	Roller dia.	PIN								Transverse pitch	Plate			ISO Min. tensile strength	DID Min. tensile strength	DID Max. Allowable load	Approx. Weight
DID	ISO	P	W	D	d	E	F	G	L	e	f	g	C	T	H	h	kN	kN	kN	kg/m
DID 25	04C					7,8	8,5										3,5	3,63	0,69	0,13
DID 25-2	04C-2	6,35	3,18	3,30	2,31	14,4	15,0	-	-	3,9	4,7	-	6,4	0,72	5,9	5,2	7,0	7,26	1,17	0,26
DID 25-3	04C-3					20,8	21,4										10,5	10,9	1,73	0,39
DID 35	06C					12,0	13,1	14,1									7,9	8,83	2,15	0,32
DID 35-2	06C-2	9,525	4,78	5,08	3,59	22,1	23,2	23,5	-	6,0	7,3	7,4	10,1	1,25	9,0	7,75	15,8	17,7	3,66	0,69
DID 35-3	06C-3					32,2	33,4	33,7									23,7	26,5	5,38	1,05
DID 40	08A					16,5	17,6	18,1	19,1								13,9	15,7	3,72	0,63
DID 40-2	08A-2	12,70	7,95	7,92	3,97	31,0	32,1	32,6	33,6	8,3	9,5	10,1	14,4	1,5	12,0	10,4	27,8	31,4	6,32	1,19
DID 40-3	08A-3					45,4	46,4	47,0	47,9								41,7	47,1	9,3	1,78
DID 50	10A					20,3	21,9	22,1	23,2								21,8	26,5	6,86	1,06
DID 50-2	10A-2	15,875	9,53	10,16	5,09	38,5	40,1	40,3	41,3	10,2	11,6	12,1	18,1	2,0	15,0	13,0	43,6	53	11,7	2,04
DID 50-3	10A-3					56,7	58,3	58,5	59,5								65,4	79,5	17,2	3,06
DID 60	12A					25,4	26,9	27,9	29,8								31,3	35,3	9,31	1,53
DID 60-2	12A-2	19,05	12,70	11,91	5,96	48,3	49,8	50,9	52,5	12,7	14,3	15,1	22,8	2,4	18,1	15,6	62,6	70,6	15,8	3,03
DID 60-3	12A-3					71,2	72,7	73,7	75,3								93,9	106	23,3	4,51
DID 80	16A					32,6		35,4	37,1								55,6	71,6	14,7	2,55
DID 80-2	16A-2	25,40	15,88	15,88	7,94	61,9	-	64,7	66,3	16,3	-	19,0	29,3	3,2	24,0	20,8	111,2	143	25,0	5,07
DID 80-3	16A-3					91,3		94,0	95,1								166,8	215	36,8	7,58
DID 100	20A					39,5		42,6	45,2								87,0	108	22,5	3,79
DID 100-2	20A-2	31,75	19,05	19,05	9,54	75,3	-	78,3	81,1	19,8	-	22,7	35,8	4,0	29,9	26,0	174	216	38,3	7,53
DID 100-3	20A-3					111,2		114,2	115,2								261	324	56,3	11,3

Note.

1. RJ type connecting links are Clearance fit type and used for DID 25- 60.
2. CJ type connecting links are Interference fit type and used for DID 80 or larger.
3. OJ type connecting links are Offset link and used for DID 40 or larger.
4. 2POJ type connecting links are Offset link and can be used for all sizes.

Dimensional drawing

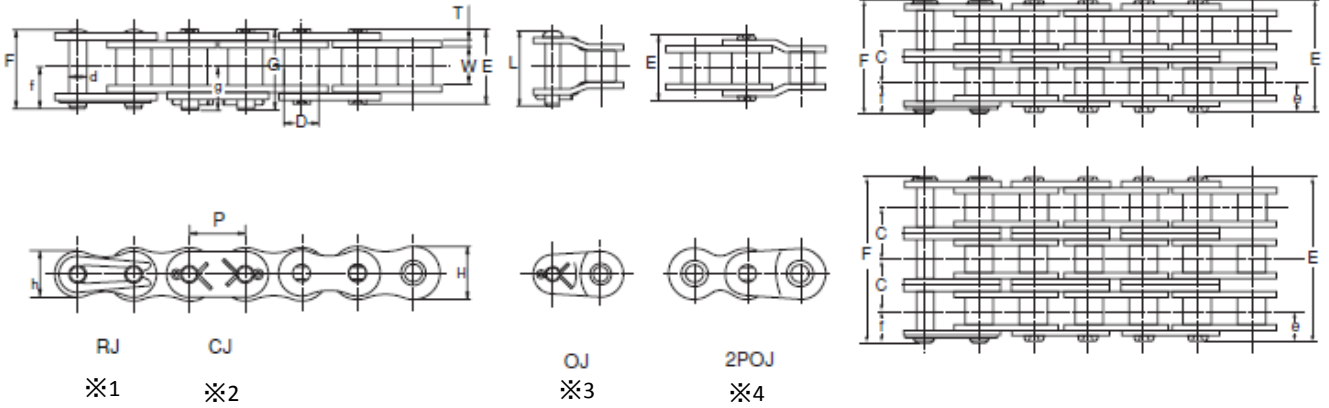

Dimensions

(mm)

Chain No.		Pitch P	Roller link width W	Roller dia. D	PIN								Transverse pitch C	Plate				ISO Min. tensile strength kN	DID Min. tensile strength kN	DID Max. Allowable load kN	Approx. Weight kg/m
DID	ISO				d	E	F	G	L	e	f	g		T	H	h					
DID 120	24A				49,7	53,0	54,0											125	148	30,4	5,49
DID 120-2	24A-2	38,1	25,4	22,23	11,11	95,2	-	98,5	99,6	24,9	-	28,2	45,4	4,8	35,9	31,2		250	296	51,7	11,0
DID 120-3	24A-3					140,6		143,9	145									375	444	76,0	16,5
DID 140	28A					53,6		58,4	59,6									170	193	40,2	7,11
DID 140-2	28A-2	44,45	25,4	25,4	12,71	102,6	-	107,4	108,6	26,8	-	31,7	48,9	5,6	41,9	36,3		340	386	68,3	14,1
DID 140-3	28A-3					151,5		156,3	157,5									510	579	101	21,1
DID 160	32A					63,6		68,2	69,7									223	245	52,9	9,82
DID 160-2	32A-2	50,8	31,75	28,58	14,29	122,2	-	126,8	128,3	31,9	-	36,5	58,5	6,4	47,8	41,4		446	490	89,9	19,4
DID 160-3	32A-3					180,8		185,4	186,9									669	735	132	29
DID 180	36A					71,5		77,3	79,3									281	333	61,7	12,7
DID 180-2	36A-2	57,15	35,72	35,71	17,46	137,4	-	143,2	145,2	35,8	-	41,6	65,8	7,1	53,8	46,6		562	666	105	25,0
DID 180-3	36A-3					203,3		209,1	211,1									843	999	154	37,3
DID 200	40A					77,9		85,0	87,3									347	431	73,5	16,5
DID 200-2	40A-2	63,5	38,1	39,68	19,85	149,6	-	156,6	159,0	39,0	-	46,0	71,6	8,0	60,0	52,0		694	863	125	32,5
DID 200-3	40A-3					221,3		228,3	230,6									1041	1.294	184	48,5
DID 240	42A					95,2		102,9	105,4									500	623	99,0	23,3
DID 240-2	42A-2	76,20	47,63	47,63	23,81	183,1	-	190,7	193,3	47,7	-	55,3	87,8	9,5	71,5	62,0		1.000	1.246	168	46,0
DID 240-3	42A-3					270,9		278,5	281,1									1.500	1.869	248	68,7

Note.

1. RJ type connecting links are used for DID 25- 60.
2. CJ type connecting links are used for DID 80 or larger.
3. OJ type connecting links are used for DID 40 or larger.
4. 2POJ offset links can be used for all sizes

D.I.D DID O-Ring/X-Ring Chain

The durability of chain is dramatically improved since grease is sealed between the pins and bushings by O-Rings/X-Rings. The O-Ring/X-Ring chain is the most dependable model of the Ultimate Life chain with its excellent wear resistance even in the conditions or environments where chain maintenance is difficult.



NL chain detail (European standard)

We developed the NL (Narrow O-ring) chain with ISO standard pin length.

1. When you cannot switch to a standard O-ring chain because of space limitation, NL chain can be applicable.

2. The abrasion performance is equal to O-ring chain.

Note.: The width of guide rail and sprocket should be narrow.

LX chain detail (European & ANSI standard)

1. DID X-Ring chain is the best value of maintenance-free chain available.

2. The patented X-Ring has half friction of normal O-Ring chain and provides great sealing performance. It keeps the dirt out and the grease inside much better than any other O-Rings.

3. Up to 2 times longer wear resistance performance compared to normal O-Ring chains.

4. Great cost savings can be achieved through longer life and less down time.

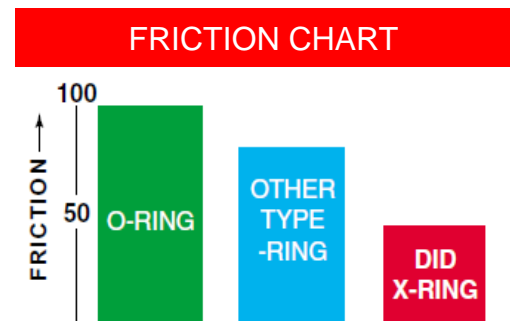
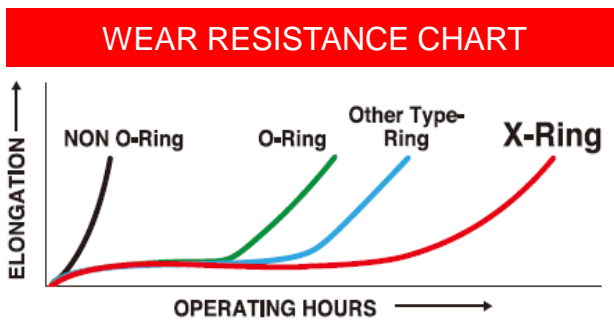

LF chain detail (ANSI standard)

1. DID X-Ring Fit chain will match to ANSI standard guide rails dimensions without any modification.

2. The abrasion performance-resistant is equal to LX chain.

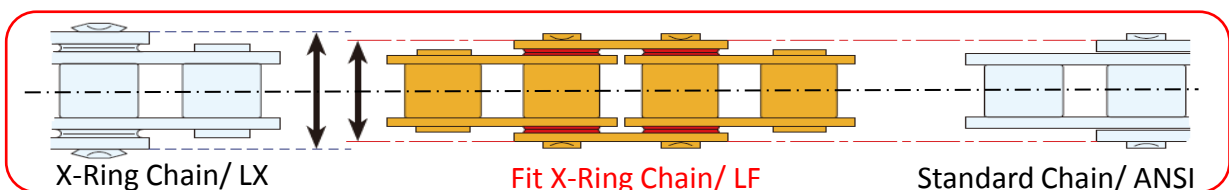

Caution: O-rings/X-rings are not recommended in applications where solvents or other substances may attack «Nitric Rubber». Please consult us for details. In general, «Nitric Rubber» is damaged by contact with the following chemical materials: Gasoline, Light oil, Benzene, Toluene, Trichloroethylene, Ether, ketone (MEK), Ethyl acetate, Phosphoric acid, Ester hydraulic oil, Organic acid, High-concentration inorganic acid.

Dimensional drawing

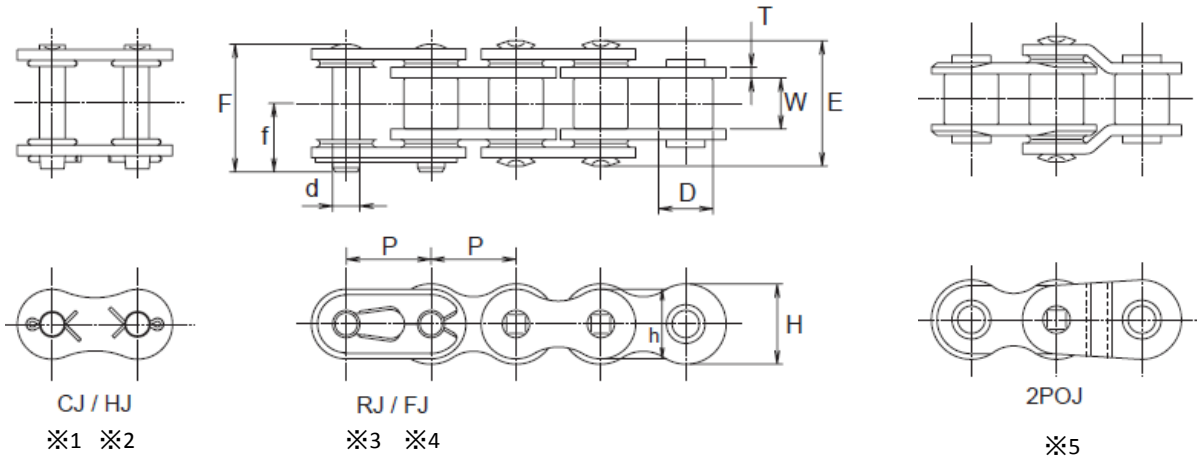

Dimensions of European standard chain

(mm)

Chain No.	Type of seal	Pitch P	Roller link width W	Roller dia. D	Pin						Plate				DID Min. tensile strength kN	Approx. Weight kg/m
					d	E	F	G	f	g	T	t	H	h		
DID 06BL	O-ring	9,525	5,72	6,35	3,28	14,15	14,70	-	7,76	-	1,3	1,0	8,2	8,2	7,84	0,40
DID 06NL			4,6			13,15	13,60	-	7,40	-						
DID 08BLX	X-ring	12,70	7,75	8,51	4,45	18,75	19,55	-	10,28	-	1,5	1,5	11,9	10,4	17,2	0,76
DID 08NL			O-ring			5,85	16,7	18,1	-	9,73				-		
DID 10BLX	X-ring	15,875	9,53	10,16	5,09	23,4	23,90	-	12,80	-	2,0	2,0	15,0	13,0	24,51	1,08
DID 10NL			O-ring			7,7	18,9	20,10	-	10,80				-		
DID 12BLX	X-ring	19,05	11,68	12,07	5,72	25,8	26,60	-	14,10	-	1,8	1,8	16,1	16,1	28,9	1,42
DID 12NL			O-ring			8,95	22,2	24,00	-	13,10				-		
DID 16BLX	X-ring	25,40	17,02	15,88	8,29	39,0	39,95	41,3	20,53	22,1	4,0	3,2	21,0	21,0	60,8	2,96

Dimensions of ANSI standard chain

(mm)

Chain No.	Type of seal	Pitch P	Roller link width W	Roller dia. D	Pin						Plate				DID Ave. tensile strength kN	Approx. Weight kg/m
					d	E	F	G	f	g	T	t	H	h		
DID 35LD	O-ring	9,525	4,60	5,08	3,59	13,0	14,45	-	7,80	-	1,25	1,25	9,0	7,75	9,80	0,35
DID 40LX	X-ring	12,70	7,95	7,92	3,97	20,0	20,0	-	10,70	-	1,5	1,5	12,0	10,4	18,1	0,67
DID 40LF						X-ring	12,70	16,5	17,6	-	9,50	-				
DID 50LX	X-ring	15,875	9,53	10,16	5,09	23,4	23,9	-	12,80	-	2,0	2,0	15,0	13,0	30,1	1,08
DID 50LF						X-ring	15,875	20,3	21,9	-	11,60	-				
DID 60LX	X-ring	19,05	12,7	11,91	5,96	29,2	30,0	-	16,00	-	2,4	2,4	18,1	15,6	42,8	1,62
DID 60LF						X-ring	19,05	25,4	26,9	-	14,30	-				
DID 80LD	O-ring	25,40	15,88	15,88	7,94	36,5	-	38,5	-	20,9	3,2	3,2	24,0	20,6	72,5	2,83

Note.

1. CJ type connecting links are Clearance fit type and used for DID 16 and DID 80
2. HJ type connecting links are Interference fit type and used for DID 16 and DID 80.
3. RJ type connecting links are Clearance fit type and used for DID 06-12 and DID 25- 60.
4. FJ type connecting links are Interference fit type and used for DID 06-12 and DID 25-60.
5. 2POJ type connecting links are Offset link and can be used for all sizes.

Ultimate Power chains are enhanced in fatigue strength and impact strength. The roller chains hold high transmission efficiency for applications from low to high speeds, and are powerful enough to withstand long-term use.



HI-PWR-S chain detail

- 1, HI-PWR-S roller chains are enhanced in fatigue strength and impact strength. Pin length has not been modified.
- 2, Plates are enlarged, and the machining accuracy and assembling accuracy of components are improved.

HK chain detail

- 1, HK roller chains conform to H type of ANSI, and their thickness of inner and outer link plates are equal to those of the next larger size chain.
- 2, HK roller chains have 10% higher tensile strength than standard roller chains.
- 3, Since the weight of the chains is also larger, HK roller chains are suitable for the application of heavy duty at low speed.

HI-PWR-S HK chain detail

- 1, HI-PWR-S HK roller chains have thicker link plates than HI-PWR-S roller chains. These chains have the highest tensile strength and allowable load among general application chains.
- 2, HI-PWR-S HK are suitable for low speed heavy duty transmission.

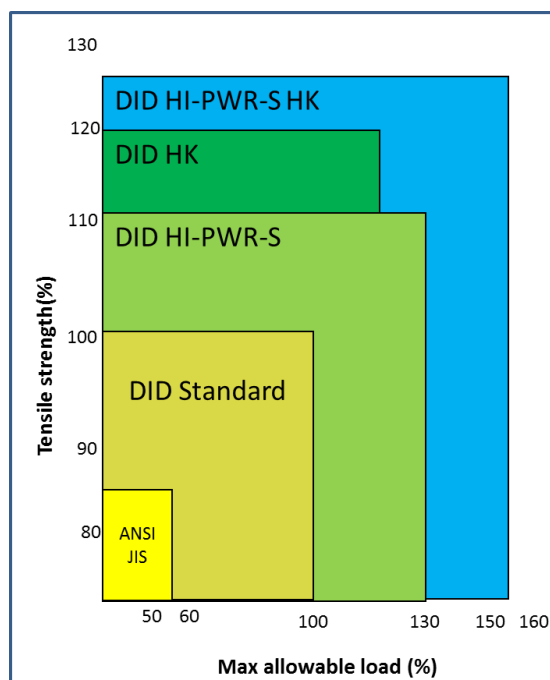

Dimensional drawing

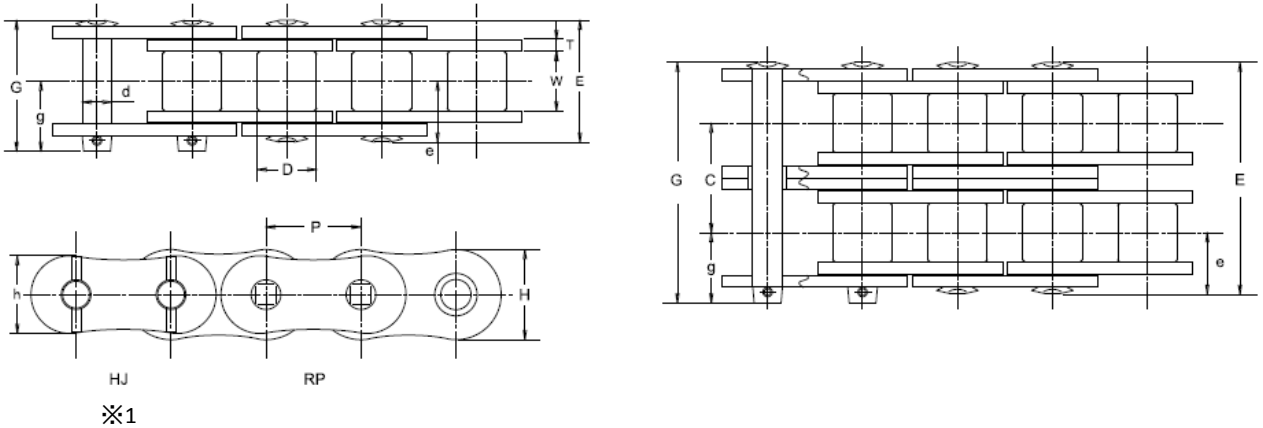

Dimensions

(mm)

Chain No.	Pitch P	Roller link width W	Roller dia. D	Pin					Transverse Pitch C	Plate			DID Min. tensile strength kN	DID Max. Allowable load kN	Approx. Weight kg/m
				d	E	G	e	g		T	H	h			
DID HI-PWR-S 80					32,6	35,4							75,6	18,6	2,82
DID HI-PWR-S 80-2	25,40	15,88	15,88	7,94	61,9	64,7	16,4	19,0	29,3	3,2	24,1	20,8	151	31,6	5,61
DID HI-PWR-S 80-3					91,3	94,0							227	46,5	8,24
DID HI-PWR-S 100					39,5	42,5							117	30,4	4,18
DID HI-PWR-S 100-2	31,75	19,05	19,05	9,54	75,3	78,3	19,8	22,7	35,8	4,0	30,1	26,0	234	51,6	8,21
DID HI-PWR-S 100-3					111,2	114,2							351	76,0	12,2
DID HI-PWR-S 120					49,7	53,0							162	40,2	6,12
DID HI-PWR-S 120-2	38,10	25,40	22,23	11,11	95,2	98,5	24,9	28,2	45,4	4,8	36,2	31,2	324	68,3	12,2
DID HI-PWR-S 120-3					140,6	143,9							486	100	18,2
DID HI-PWR-S 140					53,6	58,4							216	53,9	7,71
DID HI-PWR-S 140-2	44,45	25,40	25,40	12,71	102,6	107,4	26,8	31,7	48,9	5,6	42,2	36,3	432	91,7	15,3
DID HI-PWR-S 140-3					151,5	156,3							648	134,0	22,9
DID HI-PWR-S 160					63,6	68,2							273	70,6	10,5
DID HI-PWR-S 160-2	50,80	31,75	28,58	14,29	122,2	126,8	31,9	36,5	58,5	6,4	48,2	41,4	546	120	20,8
DID HI-PWR-S 160-3					180,8	185,4							819	176	31,2
DID HI-PWR-S 180					71,5	77,3							379	83,3	14,4
DID HI-PWR-S 180-2	57,15	35,72	35,72	17,46	137,4	143,2	35,8	41,6	65,8	7,1	54,3	46,6	758	141	28,6
DID HI-PWR-S 180-3					203,3	209,1							1137	208	42,7
DID HI-PWR-S 200					77,9	85,0							460	98,1	17,5
DID HI-PWR-S 200-2	63,50	38,10	39,68	19,85	149,6	156,6	39,0	46,0	71,6	8,0	60,3	52,0	920	166	34,7
DID HI-PWR-S 200-3					221,3	228,3							1380	245	52,0
DID HI-PWR-S 240					95,2	102,9							667	132	24,7
DID HI-PWR-S 240-2	76,20	47,63	47,63	23,81	183,1	190,7	47,7	55,3	87,8	9,5	72,3	62,0	1334	225	49,0
DID HI-PWR-S 240-3					270,9	278,5							2001	331	73,3

Note.

1. HJ type connecting links are Interference fit type with spring pin and used for DID all sizes.

Dimensional drawing

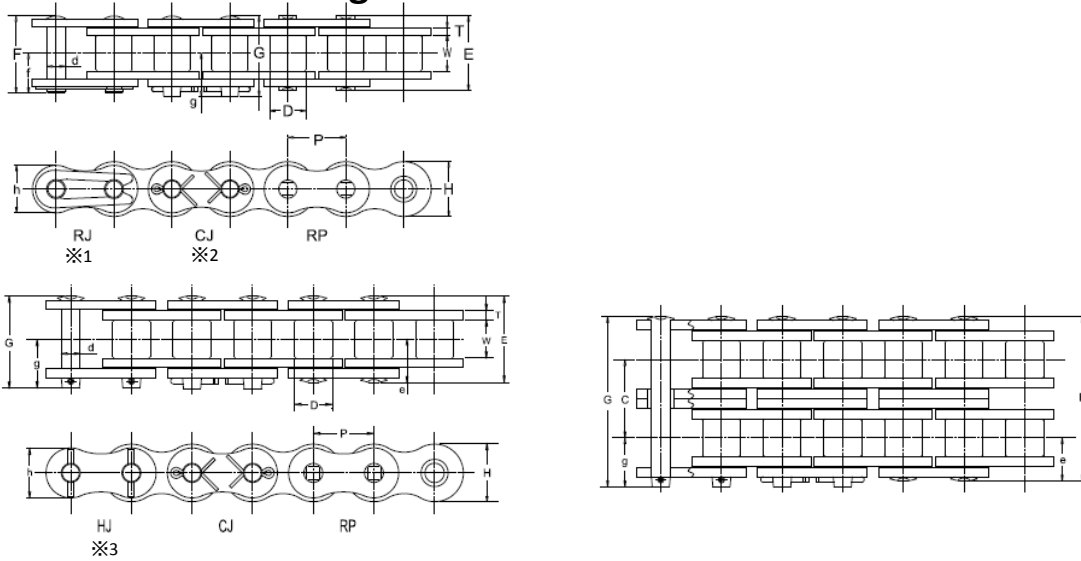

Dimensions

(mm)

Chain No.	Pitch P	Roller link width W	Roller dia. D	Pin						Transverse Pitch C	Plate			DID Min. tensile strength kN	DID Max. Allowable load kN	Approx. Weight kg/m
				d	E	F	G	e	g		T	H	h			
DID 40HK	12,70	7,95	7,92	3,97	18,5	19,5	-	10,5	-	-	2,0	12,0	10,4	19,6	4,51	0,72
DID 50HK	15,875	9,53	10,16	5,09	21,8	23,4	-	12,6	-	-	2,4	15,0	13,0	33,3	7,85	1,12
DID 60HK	19,05	12,70	11,91	5,96	28,7	30,5	31,2	16,1	16,9	-	3,2	18,1	15,6	47,1	10,7	1,81
DID 80HK					35,9	-	38,7							81,3	16,6	2,97
DID 80HK-2	25,40	15,88	15,88	7,94	68,5	-	71,3	18,0	20,6	32,6	4,0	24,0	20,8	162	28,3	5,88
DID 80HK-3					101,2	-	104,0							244	41,6	8,76
DID 100HK					42,7	-	45,8							123	26,4	4,16
DID 100HK-2	31,75	19,05	19,05	9,54	82,0	-	85,0	21,4	24,4	39,1	4,8	29,9	26,0	246	45,0	8,23
DID 100HK-3					121,1	-	124,1							369	66,1	12,27
DID 120HK					53,2	-	56,5							167	34,3	6,08
DID 120HK-2	38,10	25,40	22,23	11,11	102,2	-	105,5	26,6	29,9	48,9	5,6	35,9	31,2	334	58,3	12,04
DID 120HK-3					151,1	-	154,4							501	85,8	17,94
DID 140HK					56,9	-	61,7							217	45,1	8,81
DID 140HK-2	44,45	25,40	25,40	12,71	109,2	-	114,0	28,5	33,3	52,2	6,4	41,9	36,3	434	76,6	17,44
DID 140HK-3					161,4	-	166,2							651	113	25,99
DID 160HK					67,0	-	71,6							278	58,8	10,93
DID 160HK-2	50,80	31,75	28,58	14,29	129,0	-	133,6	33,5	38,2	61,9	7,1	47,8	41,4	556	100	21,64
DID 160HK-3					191,9	-	195,6							834	147	32,24
DID 180HK					74,9	-	80,8							402	71,5	14,81
DID 180HK-2	57,15	35,72	35,72	17,46	144,2	-	150,0	37,5	43,3	69,2	8,0	53,8	46,6	804	121	29,32
DID 180HK-3					213,5	-	219,3							1200	178	43,69
DID 200HK					84,7	-	91,7							487	83,3	19,17
DID 200HK-2	63,50	38,10	39,68	19,85	163,0	-	170,0	42,4	49,4	78,3	9,5	60,0	52,0	974	141	37,95
DID 200HK-3					241,4	-	248,4							1461	208	56,55
DID 240HK					108,5	-	116,3							768	112	28,30
DID 240HK-2	76,20	47,63	47,63	23,81	209,9	-	217,6	54,3	61,7	101,2	12,7	71,5	62,0	1536	191	56,03
DID 240HK-3					311,1	-	318,8							2304	281	83,48

Note.

1. RJ type connecting links are used for DID 25- 60.
2. CJ type connecting links are used for DID 80 or larger.
3. HJ type connecting link are Interference fit type with spring pin and used for DID 80 or larger.

Dimensional drawing

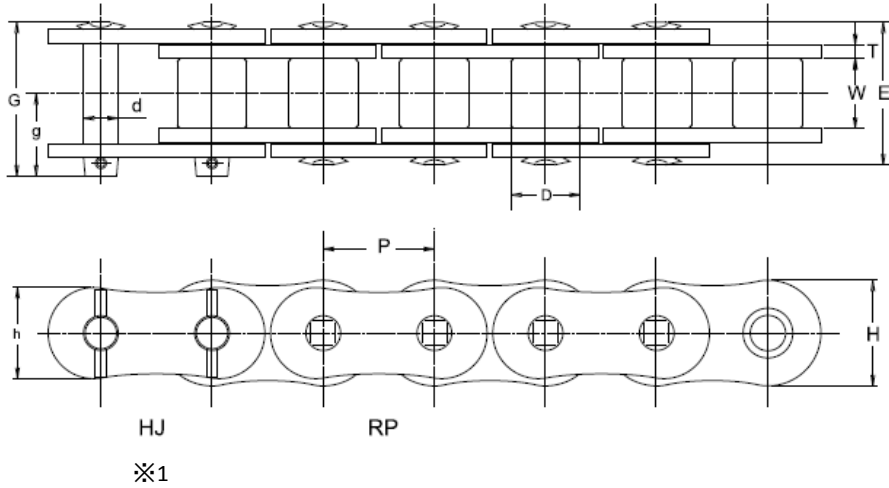

Dimensions

(mm)

Chain No.	Pitch P	Roller link width W	Roller dia. D	Pin				Plate			DID Min. tensile strength kN	DID Max. Allowable load kN	Approx. Weight kg/m
				d	E	G	g	T	H	h			
DID HI-PWR-S 80HK	25,40	15,88	15,88	7,94	35,9	38,7	20,6	4,0	24,1	20,8	85,4	22,5	3,12
DID HI-PWR-S 100HK	31,75	19,05	19,05	9,54	42,7	45,8	24,4	4,8	30,1	26,0	132	34,3	4,37
DID HI-PWR-S 120HK	38,10	25,40	22,23	11,11	53,2	56,5	29,9	5,6	36,2	31,2	171	45,1	6,39
DID HI-PWR-S 140HK	44,45	25,40	25,40	12,71	56,9	61,7	33,3	6,4	42,2	36,3	222	60,8	9,25
DID HI-PWR-S 160HK	50,80	31,75	28,58	14,29	67,0	71,6	38,2	7,1	48,2	41,4	282	77,4	11,48
DID HI-PWR-S 180HK	57,15	35,72	35,71	17,46	74,9	80,8	43,3	8,0	54,3	46,6	422	91,2	15,55
DID HI-PWR-S 200HK	63,50	38,10	39,68	19,85	84,7	91,7	49,4	9,5	60,3	52,0	520	112	20,13
DID HI-PWR-S 240HK	76,20	47,63	47,63	23,81	108,5	116,3	61,7	12,7	72,3	62,0	803	155	29,72

Note.

1. HJ type connecting links are Interference fit type with spring pin and used for DID all sizes.

D.I.D DID Double Pitch Chain

Conveyor chains are basically used for longer distances and they operated at lower speeds than transmission chains. Accordingly, even though the plate pitch is doubled to reduce the number of sprocket teeth engaged with the chain, the pins, bushings and rollers are left unchanged. The wear of pins, bushings and rollers is sensibly lower. The pins, bushings and rollers dimension and material are the same as single pitch chains.



Dimensional drawing

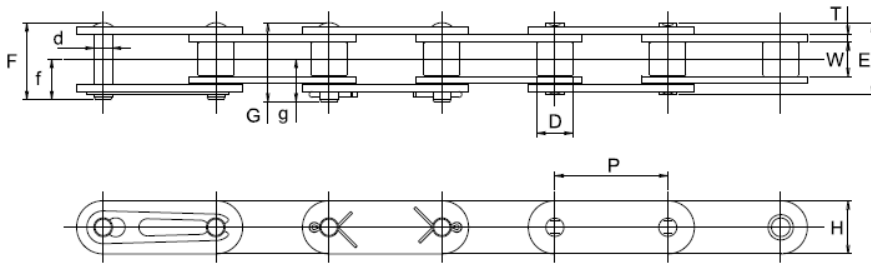

Dimensions

Chain No.	Pitch P	Roller link width W	Roller dia. D	Pin						Plate		DID Ave. tensile strength kN	DID Max. Allowable load kN	Approx. Weight kg/m
				d	E	F	G	f	g	T	H			
DID C2040	25,40	7,95	7,92	3,97	16,5	17,6	-	9,5	-	1,5	11,7	17,0	2,64	0,49
DID C2042			15,88											0,86
DID C2050	31,75	9,53	10,16	5,09	20,3	21,9	-	11,6	-	2,0	15,1	28,7	4,4	0,84
DID C2052			19,05											1,32
DID C2060H	38,10	12,70	11,91	5,96	28,7	30,1	-	15,8	-	3,2	17,2	40,2	6,47	1,45
DID C2062H			22,23											2,17
DID C2080H	50,80	15,88	15,88	7,94	35,9	-	38,7	-	20,6	4,0	23,3	68,6	11,2	2,46
DID C2082H			28,58											3,53
DID C2100H	63,50	19,05	19,05	9,54	42,7	-	45,8	-	24,4	4,8	28,8	112	18,6	3,60
DID C2102H			39,68											5,81
DID C2120H	76,20	25,40	22,23	11,11	53,2	-	56,5	-	29,9	5,6	33,8	156	25,5	5,09
DID C2122H			44,45											8,09
DID C2160H	101,60	31,75	28,58	14,29	67,0	-	71,6	-	38,2	7,1	47,4	259	42,1	8,91
DID C2162H			57,15											13,60

(mm)

Nickel Plated Chain (N)



- Special nickel plated
- Where brilliance and cleanliness are required.
- Strong corrosion resistance (highly resistant to salt water spray acidic atmosphere)

Hi-Guard Chain (E)



- High corrosion resistant film coating.
- Where long periods of seasonal inactivity need for protection against indoor or outdoor weathering.

Double Guard Chain (WG)



- Twice Rust protection than DID Hi-guard chain.
- Amazing performance in acidic and alkaline atmospheres.
- The tensile strength and working load is the same as standard chain and makes the downsizing possible where stainless steel chain is used.

Performance comparison

Name	Allowable load Index	Tensile strength Index	Corrosion resistance Times	General atmosphere (Results of CASS test)	Water and Salt water	Alkaline resistance	Acidic resistance
Standard	100%	100%	1	△	× (Rusting)	△	× (Cracking)
Nickel Plated (N)	100%	100%	3	○	△	○	△
Hi-Guard (E)	100%	90%	60	○	○	△	×
Double Guard (WG)	100%	90%	120	◎	◎	○	△
Stainless Steel (SS)	10%	70%	-	◎	◎	◎	◎

Note: ◎: Excelent, ○: Very good, △: Good, ×: No good

Dimensional drawing

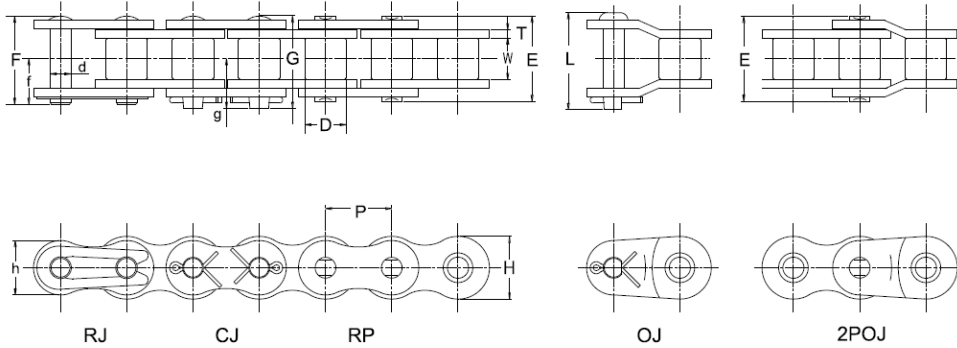

Dimensions

Nickel plated chain (N): Range 04B~16B, 25~120

Chain No.	Pitch P	Roller link width W	Roller dia. D	Pin								Plate		DID Average Tensile strength	DID Max allowable load	Approx. Weight
				d	E	F	G	f	g	L	T	H	h			

All dimensions are the same as DID standard roller chain (P3 and P4 of this catalogue)

Hi-Guard Chain (E): Range 06B~16B, 35~120

(mm)

Chain No.	Pitch P	Roller link width W	Roller dia. D	Pin								Plate		DID Average Tensile strength	DID Max allowable load	Approx. Weight
				d	E	F	G	f	g	L	T	H	h			
DID 35 ※1	9,525	4,78	5,08	3,59	12,0	13,1	-	7,3	-	13,9	1,25	9,0	7,75	10,2	2,15	0,32
DID 40E	12,70	7,95	7,92	3,97	16,5	17,6	-	9,5	-	19,3	1,50	12,0	10,4	16,6	3,72	0,63
DID 50E	15,875	9,53	10,16	5,09	20,3	21,9	-	11,6	-	23,1	2,00	15,0	13,0	28,4	6,86	1,06
DID 60E	19,05	12,70	11,91	5,96	25,4	26,9	-	14,3	-	30,0	2,40	18,1	15,6	40,2	9,31	1,44
DID 80E	25,40	15,88	15,88	7,94	32,6	-	35,4	-	19,0	37,1	3,20	24,0	20,8	75	14,7	2,55
DID 100E	31,75	19,05	19,05	9,54	39,5	-	42,5	-	22,7	45,3	4,00	29,9	26,0	112	22,5	3,79
DID 120E	38,10	25,40	22,23	11,11	49,7	-	53,0	-	28,2	54,1	4,80	35,9	31,2	157	30,4	5,49

Note.

1. DID 35 is bushing chain.

Double Guard Chain (WG): Range 06B~16B, 40~80

(mm)

Chain No.	Pitch P	Roller link width W	Roller dia. D	Pin								Plate		DID Average Tensile Strength	DID Min. Tensile Strength	Approx. Weight
				d	E	F	G	f	g	L	T	H	h			
DID 40WG	12,70	7,95	7,92	3,97	16,5	17,6	-	9,5	-	19,1	1,50	12,0	10,4	16,6	3,72	0,63
DID 50WG	15,875	9,53	10,16	5,09	20,3	21,9	-	11,6	-	23,1	2,00	15,0	13,0	28,4	6,86	1,06
DID 60WG	19,05	12,70	11,91	5,96	25,4	26,9	-	14,3	-	30,0	2,40	18,1	15,6	40,2	9,31	1,44
DID 80WG	25,40	15,88	15,88	7,94	32,6	-	35,4	-	19,0	37,1	3,20	24,0	20,8	75	14,7	2,55

Stainless Steel chain

(SS)

(SSK)



- SUS 304
- Where chains is exposed to chemical water and high temperature.
- The best resistance to corrosion and heat.
- Range: 06B~16B, 25~100

- SUS 304 (plate) + SUS 631 (pin, bushing and roller).
- Where chain is exposed to chemical, water and high temperature.
- Max allowable load 1,5 times higher than SS type.
- Range: 40~80

Stainless Steel X-Ring chain (SSLT)

- Wear resistance performance is 10 times greater than standard stainless steel chain.
- Big cost saving can be achieved through long life and less maintenance time.
- The patented X-Ring provides great sealing performance and half friction of standard O-Ring.
- Range: 40~80

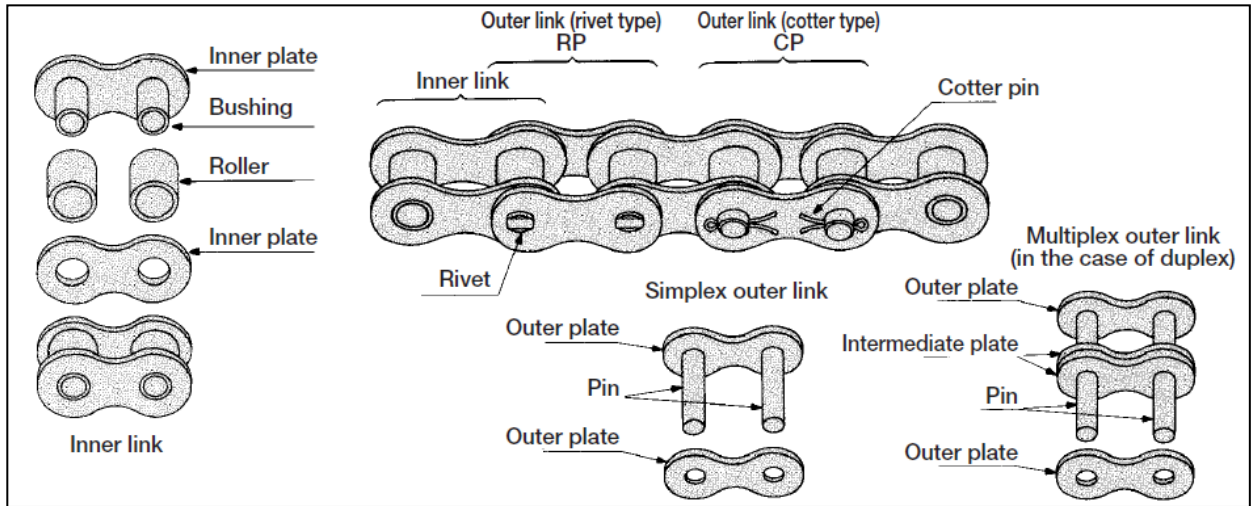

Clip type connecting link

Outer plate
Connecting pin
Connecting plate
Clip

Clip type connecting link in which the connecting pins are clearance-fitted with the connecting plate is called an **R** connecting link (**RJ**), and that, interference-fitted, is called an **F** connecting link (**FJ**).

Cotter pin type connecting link

Outer plate
Connecting pin
Connecting plate
Cotter pin

A cotter type connecting link in which the connecting pins are clearance-fitted with the connecting plate is called a **C** connecting link (**CJ**), and that, interference-fitted, is called an **H** connecting link (**HJ**).

Spring pin type connecting link

Outer plate
Spring pin type connecting pin
Connecting plate
Spring pin

In a standard spring pin type connecting link, the connecting pins are interference-fitted with the connecting plates (**H** connecting link). **HI-PWR-S**, **HK** and **HI-PWR-SHK** series adopt this type.

Offset plate
Offset pin
Cotter pin
One-pitch offset link (**OJ**)
Offset plate
Two-pitch offset link (**2POJ**)

Four types of connecting links are available: RJ, FJ, CJ and HJ

Clearance fit: RJ and CJ

In this fit, a clearance is always formed between the pin and the hole when they are assembled. This method is used in standard connecting link.

Interference fit: FJ and HJ

In this fit, an interference always occurs when the pin and the hole are assembled. This method is used for base chains and HJ type connecting links. However, for HJ connecting links, the interference is smaller than that of base chains.

Offset links: OJ and 2POJ

An offset link is used for increasing or decreasing the length of a chain by one pitch. 2 types of offset links are available: OJ and 2POJ

1. To order DID 60LX with 160 links and one RJ type connecting link as a loop.

[Type indication]

DID 60LX × **160** **R E**

DAIDO's product
Size of chain
Type of chain (LX indicates an O-ring chain)

Chain No.

Indicates that the overall length of chain is 160 links.

Length

Conditions of connecting link.

- A part from the chain. ----- B :
- Connected with the chain to form a loop. ----- E :
- Connected with the chain to form a straight shape. ----- T :

Chain direction

Clip type ----- R : Clearance fit, F : Interference fit
Cotter pin type -- C : Clearance fit, H : Interference fit

Some are inapplicable, depending on the chain size.

Type of connecting link.

Packaging

2. To order DID 80CP with 117 links, three offset (OJ) type connecting links and one CJ type connecting link as a straight chain.

DID 80CP × **117LL** + **OJ × 3** + **CJ** +

DAIDO's product
Size of chain
Type of chain
Method for connecting pins and plates.
Rivet : RP
Cotter pin : CP (No expression means RP)

Chain No.

Indicates that the number of inner links from one end to the other end of a chain is 117.

Length

Indicates that 3 offset links (OJ) are required.

If the components stated before and after this symbol position are to be connected when the chain is delivered, [+] (plus) sign is used, and if not connected, [,] (comma) sign is used.

This symbol means that the last link is connected with the first link (to form a loop).

Indicates a C connecting link.

3. To order DID C2050 with 96 links, with bent attachments (one – hole) on both sides very two links, with a connecting link attached (in straight shape).

DID C2050 **2P** **K1** × **96** **RT**

DAIDO's product
Type of chain

Chain No.

Attachment intervals

Indicates that the overall length of chain is 96 links.

Number of holes on attachment.

Types of attachments.
K : Bent attachments are installed on both sides.
A : Bent attachments are installed on one side.
SK : Straight attachments are installed on both sides.
SA : Straight attachments are installed on one side.

Attachments

Conditions of connecting link.

- A part from the chain. ----- B :
- Connected with the chain to form a loop. ----- E :
- Connected with the chain to form a straight shape. -- T :

Type of connecting link.

R : Clip type (DID60 or DIDC2060H or smaller)
C : Cotter type (DID80 or DIDC2080H or larger)

Connecting Link

4. To order for a cotter type connecting link of DID80, in which the pins are clearance-fitted with the upper plate:

DID 80 . CJ

Chain No.

Type of connecting link.

Indicates a connecting link.

5. To order for an offset link of DID60:

DID 80 . OJ

Chain No.

Indicates an offset link.
One-pitch type: OJ
Two-pitch type: 2POJ

6. To order for a cotter type connecting link of DID80HK, in which the pins are clearance fitted with the upper plate:

DID 80HK . HJ

Chain No.

Type of connecting link.

Indicates a connecting link.

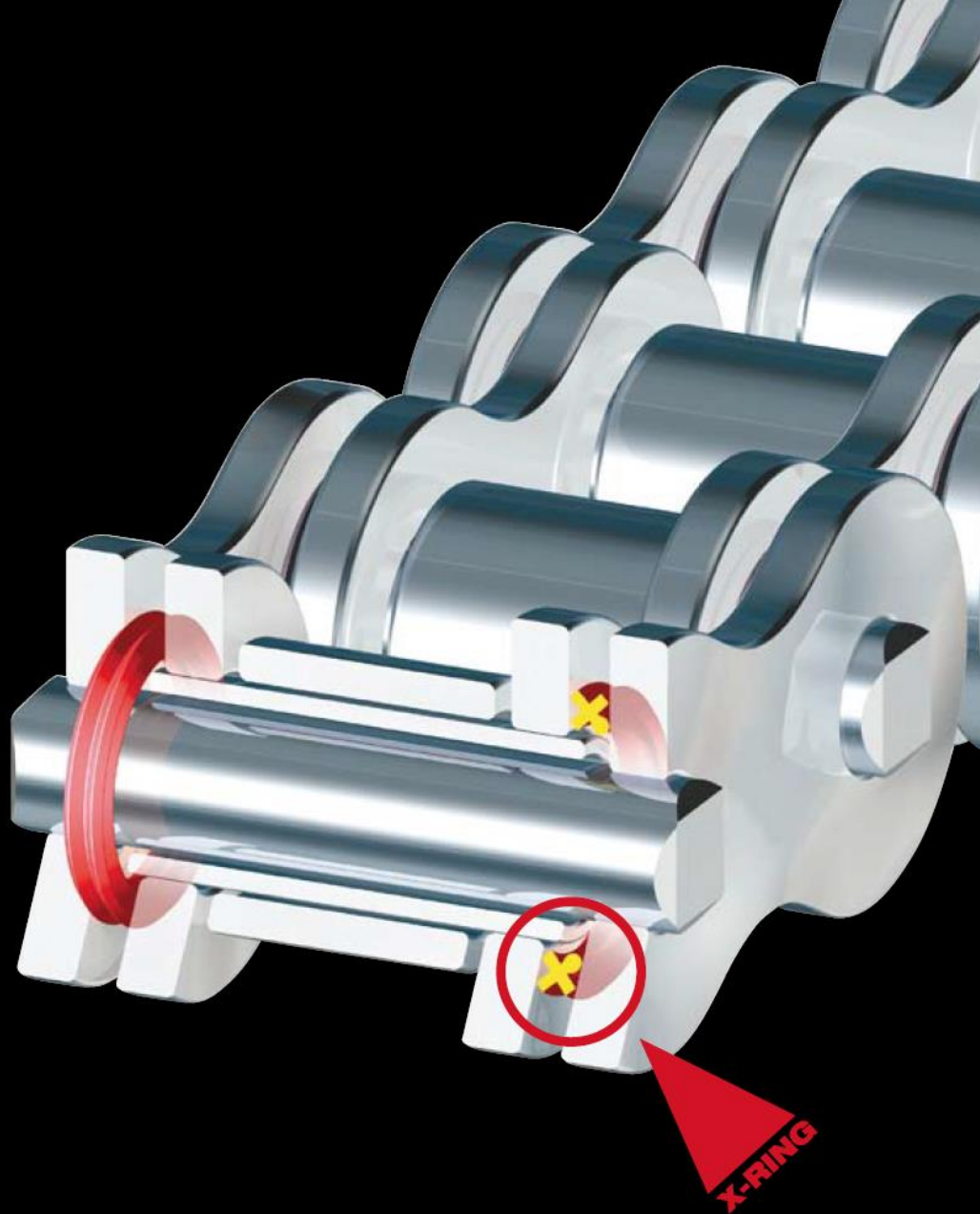

D.I.D.[®]
New Tech Chain
DRIVEN TO SOLUTIONS

Via del Fonditore, 16 40138
Bologna, Italy
Tel +39.051.531543
Fax +39.051.6014912
www.dideu.it

Distributed by :

Note) To consistently improve our products, the specifications in this catalogue are subject to change without any notice.

©DID Europe Srl. 2017 All Rights Reserved.
Printed in Italy 0117 1701A01-A