

New!

PRODUCT NEWS

D.I.D.[®]

D.I.D UR⁺(PLUS) Roller Chain

Ultimate Life Chain Series

Upgraded sintered bushing roller chain !!

Improvement points!

Food Grade Oil

NSF-H1 Food grade lubricant is standard.

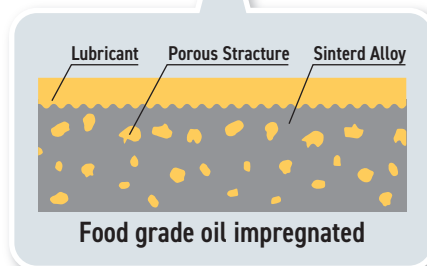
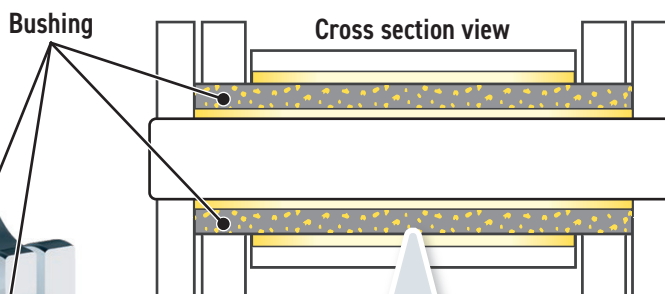
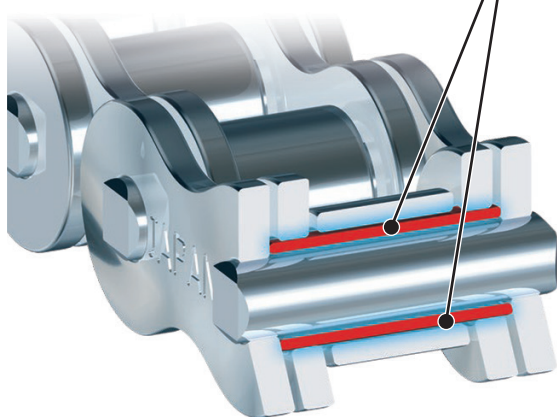

Maximum Temperature

Lube-free temperature range expand to 150°C, an 80% increase. (Operating temperature range : -10°C to 150°C)

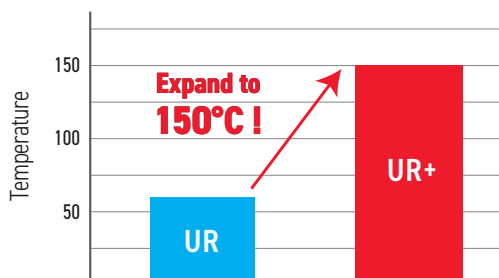

Longer Wear life

The amount of impregnated oil will increase thanks to the new bushing structure.

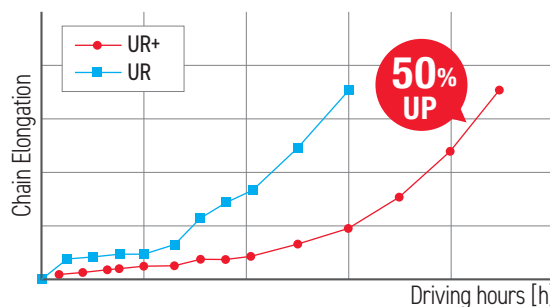

- Clean Areas
- Maintenance-Free
- Allowable Load 100%
- Temperature Range in Use -10~150°C

- FOOD
- PACK
- TEXTILE
- PRINT
- CONVEYOR
- HOME APPLIANCE



D.I.D UR⁺(PLUS) Roller Chain



Sinterd Bushing Roller Chain /UR⁺,UR⁺N for Power Transmission

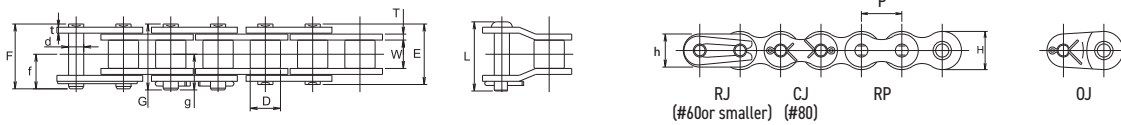

Chain		Pitch P	Inner Link inner Width W	Roller Dia. D	Pin						Plate				Avg. Tensile Strength kN	Avg. Tensile Strength kgf	Max. Allowable Load kN	Max. Allowable Load kgf	Approx. Weight (kg/m)	
Standard	Nickel Plated				d	E	F	G	L	f	g	T	t	H						h
DID 40UR ⁺	DID 40UR ⁺ N	12.70	7.95	7.92	3.97	17.7	19.0	-	21.2	10.2	-	2.0	1.5	12.0	10.4	17.8	1,810	3.72	380	0.69
DID 50UR ⁺	DID 50UR ⁺ N	15.875	9.53	10.16	5.09	21.2	22.8	-	25.0	12.3	-	2.4	2.0	15.0	13.0	29.9	3,040	6.86	700	1.09
DID 60UR ⁺	DID 60UR ⁺ N	19.05	12.70	11.91	5.96	27.2	28.9	-	33.1	15.8	-	3.2	2.4	18.1	15.6	42.1	4,270	9.31	950	1.71
DID 80UR ⁺	DID 80UR ⁺ N	25.40	15.88	15.88	7.94	34.2	-	37.1	39.7	-	20.0	4.0	3.2	24.0	20.8	77.0	7,820	14.7	1,490	2.80

Sinterd Bushing Roller Chain /C**UR⁺,UR⁺N for Small conveyor

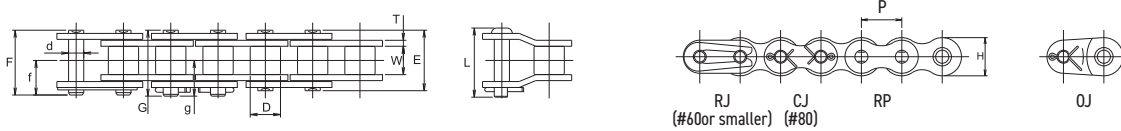

Chain		Pitch P	Inner Link inner Width W	Roller Dia. D	Pin						Plate		Avg. Tensile Strength kN	Avg. Tensile Strength kgf	Max. Allowable Load kN	Max. Allowable Load kgf	Approx. Weight (kg/m)	
Standard	Nickel Plated				d	E	F	G	L	f	g	T						H
DID C40UR ⁺	DID C40UR ⁺ N	12.70	7.95	7.92	3.97	16.5	17.6	-	19.1	9.5	-	1.5	12.0	15.6	1,580	2.64	270	0.63
DID C50UR ⁺	DID C50UR ⁺ N	15.875	9.53	10.16	5.09	20.3	21.9	-	23.2	11.6	-	2.0	15.0	25.4	2,580	4.31	440	1.06
DID C60UR ⁺	DID C60UR ⁺ N	19.05	12.70	11.91	5.96	25.4	26.9	-	29.8	14.3	-	2.4	18.1	37.2	3,780	6.27	640	1.53
DID C80UR ⁺	DID C80UR ⁺ N	25.40	15.88	15.88	7.94	32.6	-	35.4	37.1	-	19.0	3.2	24.0	68.6	6,960	10.7	1,090	2.67

Attachment

The figures show RJ type CL and #80 comes with CJ type CL.

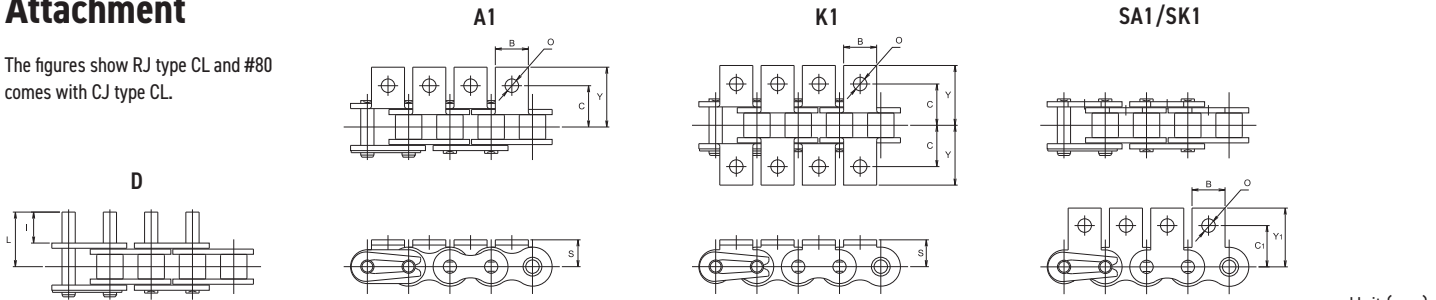

Chain		A1,K1			SA,SK		Common Dimintions		D		Approx. additional weight per attachment(kg)		
Standard	Nickel Plated	C	Y	S	C ₁	Y ₁	B	O	I	L	A,SA	K,SK	D
DID C40UR ⁺	DID C40UR ⁺ N	12.7	17.6	7.92	12.7	17.5	9.53	3.5	9.5	16.8	0.002	0.004	0.001
DID C50UR ⁺	DID C50UR ⁺ N	15.88	23.0	10.31	15.88	22.6	12.7	5.2	11.9	21.0	0.003	0.006	0.002
DID C60UR ⁺	DID C60UR ⁺ N	19.05	27.0	11.91	18.26	26.2	15.88	5.2	14.3	25.7	0.006	0.012	0.003
DID C80UR ⁺	DID C80UR ⁺ N	25.4	34.9	15.88	24.61	34.05	19.05	6.8	19.1	33.9	0.011	0.022	0.007

*1. The letter "C" following "DID" indicates that the chain is designed for conveyor systems, and the thickness of the inner plate is the same as that of the outer plate. (The inner plate of a drive chain is thicker.) *2. Please note that the surface layer of the UR⁺N may peel off from the sliding part during operation. *3. Please set the chain feeding speed to 150m/min. or lower. *4. Some assembly oil or rust prevent oil that does not comply with NSF-H1 standards may adhere during the manufacturing process. *5. The UR⁺ comes with standard pins and the UR⁺N comes with nickel plated pins. *6. Please be aware when using in environments where wear debris may become a contamination issue.



Distributed By :

I-197 Kumasaka-machi,
Kaga Ishikawa 922-8686, Japan
Web : <https://did-coltd.com/english/>